



PU 239 – 5/16/2014

## New From RegO - A7914 2" FNPT X 3-1/4" ACME Low Emission Hose End Valve for loading Bobtails and Transports

### Application

The A7914 minimum loss valve is designed to reduce the amount of product vented when disconnecting bobtail and transport loading hoses. This valve provides a full-on flow when pressing the release trigger and the lifting of an easy grip handle.

Lowering the handle will immediately stop flow and lock the lever in the closed position. This valve was designed to be used with our 6588LE and 6589LE 3-1/4" M-ACME minimum loss filler valves but can be used with any standard 3-1/4" Male ACME connector.

### Features



- Minimizes product discharge at disconnect
- When used with our 6588LE or 6589LE filler valves it vents less than 19.5cc of liquid when disconnected.
- Contoured handle rotates 360° large easy to turn ACME swivel connector.
- Self-locking handle is operator opened and closed designed to prevent accidental opening of the valve.
- Bypass mechanism in the seat area allows the upstream pressure to quickly equalize when the handle is partially moved to the open position.
- Spring loaded Teflon "V" packing for bonnet/stem assembly provides long service life.

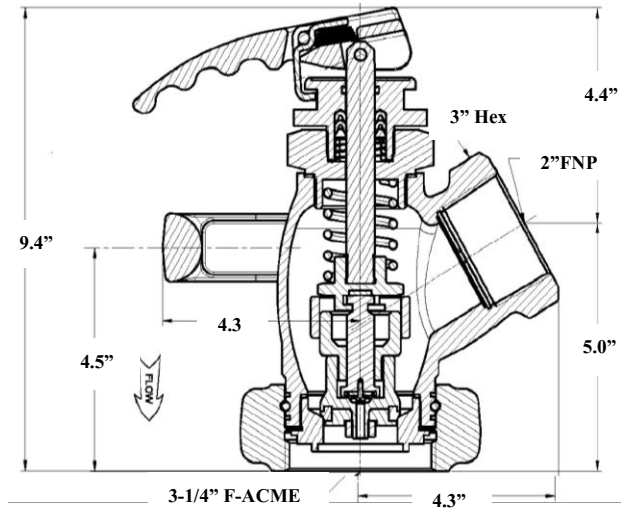

### Materials

- Body.....Ductile Iron
- "V" –Rings.....Teflon
- Stem.....Stainless Steel
- Acme Connector..... Cadmium Plated Ductile Ir
- Seal Housing.....Stainless Steel
- Bonnet.....Cadmium Plated Steel
- Lever.....Stainless Steel
- Seat Disc.....Synthetic Rubber



### Ordering Information

Part Number	Inlet Connection	Outlet Connection	Locking Handle	Flow at (Cv) Pressure Drop* GPM Propane	
				1 PSIG	10 PSIG
A7914	2" FNPT	3-1/4" F-ACME	Yes	55	174

\*To obtain approximate flow at other than 1 PSIG drop, multiply flow in table by square root of pressure drop. Example A7914 @ 9PSIG drop = 55 X √9 = 165 GPM /propane