



100 RegO Drive PO Box 247 Elon, NC 27244 USA Phone (336) 449-7707 Fax (336) 449-6594 www.regoproducts.com

A7575L Series Inspection 8/2/13

We were recently requested to provide a minimum dimension for the retaining collar on the tail piece of our A7575L Series 1-3/4" ACME adapters used for filling LPG and NH3 containers. **The minimum thickness we recommend is 0.100" (2.54 mm); if the thickness drops below this point immediately remove from service and replace.** If you have any questions on this procedure please contact us.

To inspect the collar (1)remove the retaining clip, (2)slide the handle back from the retaining collar, (3)with a set of calipers or other suitable device, measure the thickness of the collar as shown below.

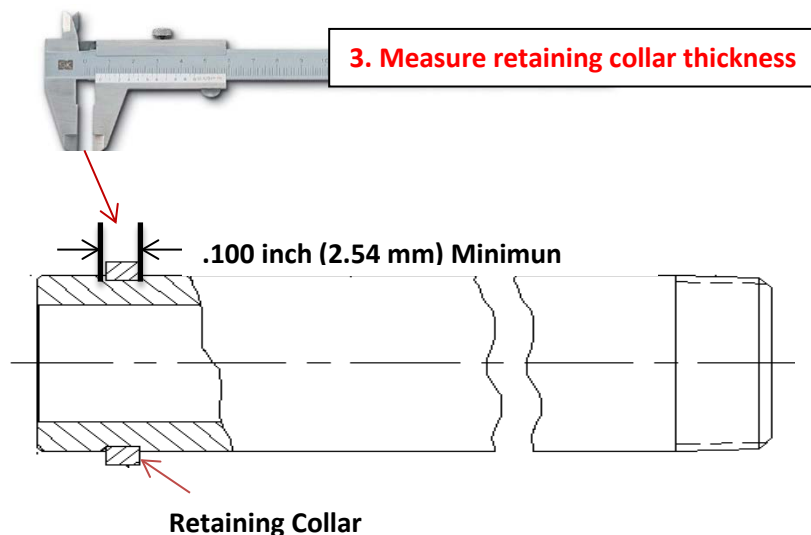
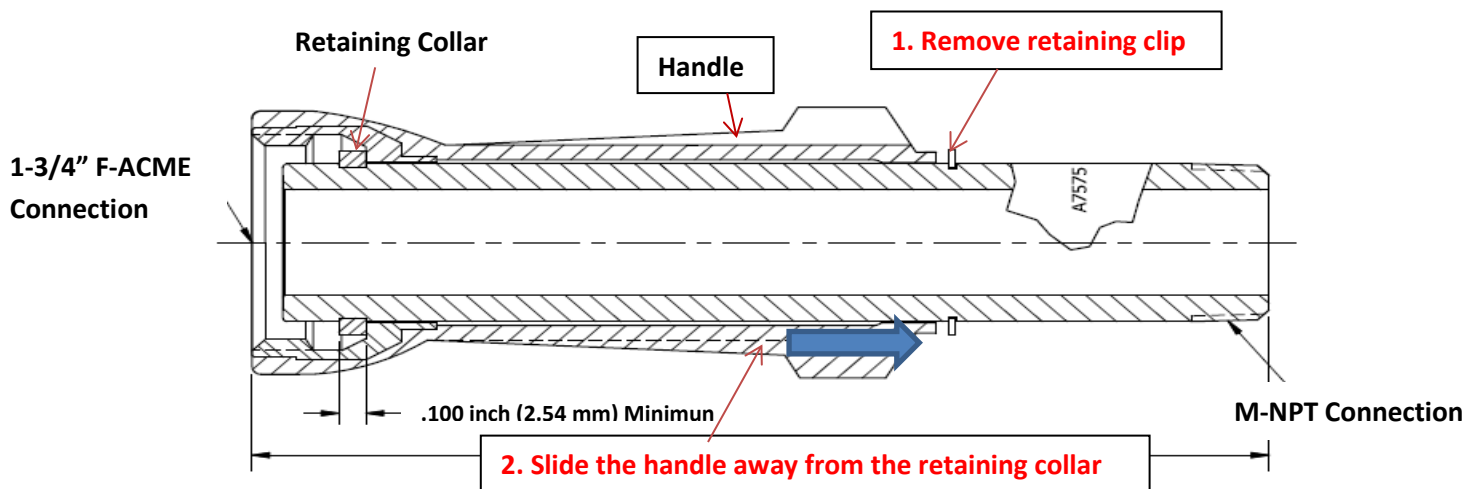

Warning

All ECII® products are mechanical devices that will eventually become inoperative due to wear, corrosion and aging of components made of materials such as rubber. The environment and conditions of use will determine the safe service life of these products. Periodic inspection and maintenance are essential to avoid serious injury and property damage.

Many ECII® products are manufactured for storage, transport, transfer and use of toxic flammable and dangerous liquids and gases. Such substances should be handled by experienced and trained personnel only, using accepted governmental and industrial safety procedures. Never vent LP-Gas near any possible source of ignition.